



SUBMITTAL DATA: AD3-D D FRAME ADSORPTION CHILLER

Job Name:	Location:	Date:
Purchaser:	Engineer:	
Submitted to:	Approval:	Date:
Submitted by:	Schedule No.:	

GENERAL FEATURES:

- ▶ Ultra low electricity consumption
- ▶ Zero ozone depletion potential
- ▶ No dangerous chemicals
- ▶ Very few moving parts
- ▶ Ease of maintenance
- ▶ Advanced microprocessor control
- ▶ Designed for outdoor installation
- ▶ Wide temperature ranges allowed

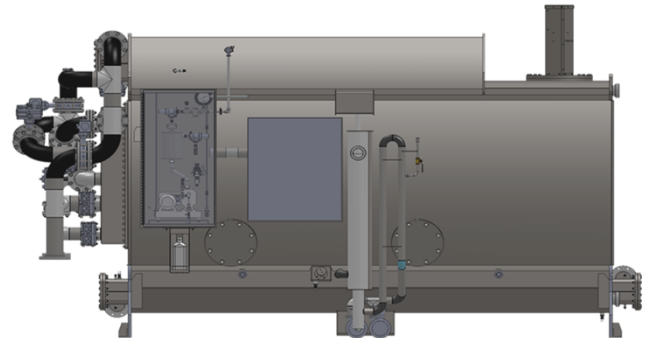
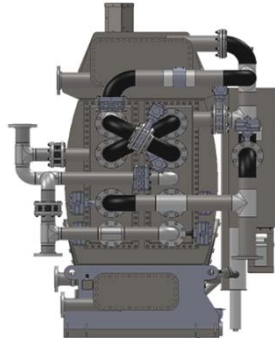

MODEL	D-75	D-60	D-50
Rated Capacity (Tons)	76	61	51

Chilled Water:

Inlet Temperature (°F)	55	55	55
Outlet Temperature (°F)	45	45	45
Flow Rate (gpm)	182	146	122
Pressure Drop (ft. H ₂ O)	28	21	17

Condenser Water:

Inlet Temperature (°F)	85	85	85
Outlet Temperature (°F)	95	95	95
Flow Rate (gpm)	549	441	369
Pressure Drop (ft. H ₂ O)	39	29	23

Hot Water:

Inlet Temperature (°F)	195	195	195
Outlet Temperature (°F)	183	183	183
Flow Rate (gpm)	304	244	204
Pressure Drop (ft. H ₂ O)	14	11	8

*Rated for maximum capacity mode. Higher efficiencies are available at reduced capacities.

*All data is preliminary and subject to change without notice.

Electrical

Voltage:..... 208/230-3-60
 Frequency:..... 60 Hz
 Operating kW Consumption:..... 0.8 kW
 Maximum kW Consumption..... 1.9 kW

Air Supply

Air Pressure:..... 71 psi
 Air Consumption:..... 0.34 cfm

Unit Dimensions*

Width..... 85"
 Length..... 199"
 Height..... 115"
 *with cabinets mounted on the side as shown

Weight

Empty:..... 26,000 lbs
 Operating:..... 29,000 lbs

Refrigerant type:..... Tap Water (H₂O)

Operating Range

Chilled Water..... 38 °F to 68 °F
 Hot Water..... 125 °F to 200 °F
 Condenser Water..... 50 °F to 102 °F
 Maximum Pressure..... 70 psig

*Maximum pressure 70 psig for hot, chilled, & condenser water

Notes:

DIMENSIONS: AD3-D

D FRAME ADSORPTION CHILLER

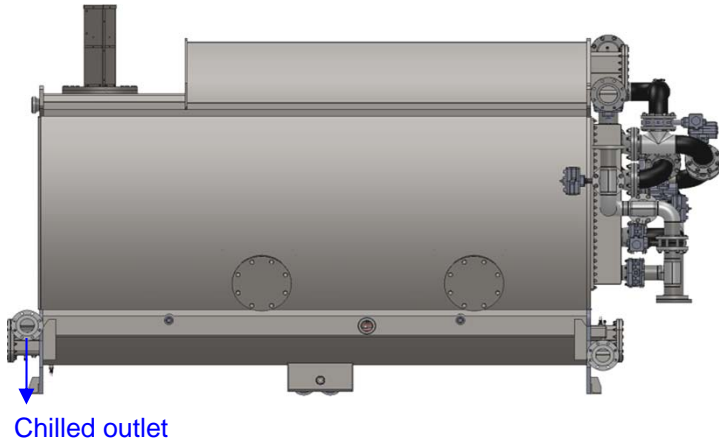

LEFT SIDE

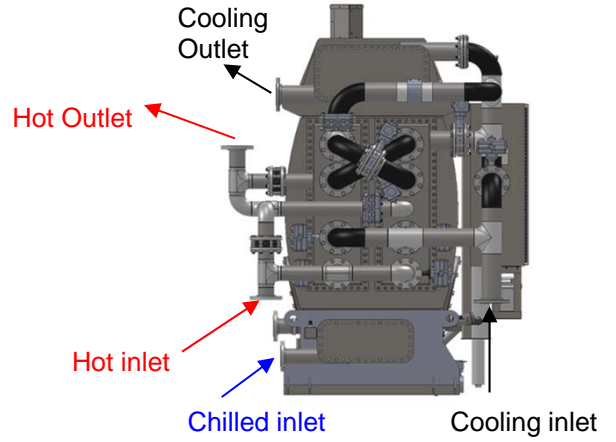

FRONT

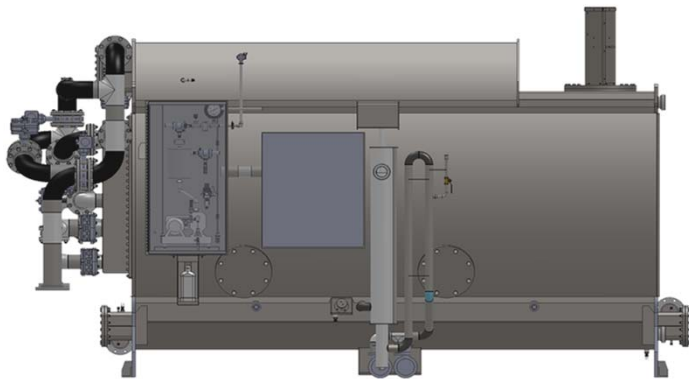

RIGHT SIDE

Connection Sizes*

	Inlet	Outlet
Chilled.....	4"	4"
Condense.....	5"	5"
Hot.....	4"	4"

*All are ANSI flanged connections

Field Notes:

Chiller must be leveled upon installation with included leveling bolts.
 Three-way control valves are NOT required for field piping.
 Minimum 30" clearance required in front of the chiller.
 The piping configuration shall provide clear access to the chiller.
 Installation and water treatment per IOM required.

Specifications are subject to change without notice.